

Evaluates: MAX17703 in 4.2V Li-Ion Battery Charger Application

MAX17703EVKITA# Evaluation Kit

General Description

The MAX17703EVKITA# (EV kit) provides a proven design to evaluate the MAX17703 high-efficiency, high-voltage, Himalaya synchronous step-down DC-DC Li-ion charger controller. The EV kit charges the Li-ion battery in constant current (CC) and constant voltage (CV) states and terminates in a topup-charge state after the taper timer is elapsed. The EV kit is designed to charge the Li-ion battery with 10A CC mode charging current (I_{CHGMAX}) and 4.2V CV mode voltage (V_{OUT}) from an 6.3V to 60V input supply. The EV kit is optimized for a 24V nominal input application. The switching frequency of the EV kit is set at 350kHz (f_{SW}) for optimum efficiency and component size. The EV kit features a safety timer (TMR) to set the maximum allowed CC mode and CV mode charging time. The EV kit also features battery temperature sensing and charges only when the temperature is in the allowable charging temperature range. For more details about the IC benefits and features, refer to the MAX17703 IC data sheet.

[Ordering Information](#) appears at end of data sheet.

Features

- Operates from an 6.3V to 60V Input Supply
- 10A CC Mode Charging Current
- 4.2V CV Mode Charging Voltage
- 350kHz Switching Frequency
- Resistor-Programmable UVLO Threshold (EN/UVLO)
- Input-Short Protection
- 3V Programmed Deeply Discharged Battery Detection
- Capacitor Programmed 10.4 hours Safety Timer
- Charge Termination on Full Battery Detection with Taper Current Threshold and Taper-Timer
- Cycle-by-Cycle Overcurrent Limit
- External Clock Synchronization (RT/SYNC)
- Charger Status Flags (FLG1, FLG2)
- Charging Current Monitoring (ISMON)
- Battery Temperature Sensing and Charge when Within Operating Temperature Range +5°C to +45°C
- IC Overtemperature Protection
- Complies with CISPR 32 (EN55032) Class B Conducted and Radiated Emissions
- Proven PCB Layout
- Fully Assembled and Tested

MAX17703EVKITA# Evaluation Kit

Quick Start

Recommended Equipment

- MAX17703EVKITA#
- 60V, 10A DC input-power supply (PS1)
- 4.2V, 45Ahr Li-ion battery with 15mΩ battery charging resistance
(or)
25A DC power supply (PS2) and 12A DC electronic load (LOAD)
- Four digital voltmeters (DVM)

Equipment Setup and Test Procedure

The EV kit is fully assembled and tested. Follow the steps below to verify board operation.

Caution: Do not turn on the power supply until all connections are completed. Carefully make the connections to avoid the battery short circuit at the output. Do not operate the EV kit without battery or preloaded supply.

The battery charger can be tested in two different ways, either with a battery or preloaded supply (power supply with electronic load).

Testing with Battery:

- 1) Set the power supply at a voltage between 6.3V and 60V. Disable the power supply (PS1).
- 2) Make sure that the battery has an open circuit voltage of 3.5V.
- 3) Connect PS1 and Li-ion battery to the EV kit as shown in [Figure 1](#).
- 4) Verify that the shunts are installed across pins 1–2 on all jumpers: charger enable/disable jumper (J1), CC mode charging current jumper (J2), TEMP feature jumper (J3), and safety timer jumper (J4). See [Table 1](#), [Table 2](#), [Table 3](#), and [Table 4](#) for details.
- 5) Connect the digital voltage meter (DVM1) between the ISMON PCB pad and the nearest SGND PCB pad for monitoring the charging current. Connect DVM2 between the VOUT PCB pad and the nearest PGND PCB pad for measuring the charging voltage.
- 6) Connect the DVM3 between the FLG1 PCB pad and the nearest SGND PCB pad for monitoring the charger status.

Evaluates: MAX17703 in 4.2V Li-Ion Battery Charger Application

- 7) Connect the DVM4 between the FLG2 PCB pad and the nearest SGND PCB pad for monitoring the charger status. See [Table 5](#) for details.
- 8) Turn on the DC power supply.
- 9) The charger starts in CC state and the safety timer starts counting. Verify that the DVM1 displays 1.5V, proportional to a 10A charging current (I_{CHGMAX}).
- 10) In CC state, observe that DVM3 and DVM4 displays 0V and 5.1V, respectively.
- 11) When the charging voltage reaches above 4.1V, the charger enters CV state, and the charging current starts to fall from 10A. Verify that when DVM2 displays above 4.1V, the voltage reading on DVM1 falls from 1.5V, proportional to the charging current.
- 12) When the charging current falls below 1A within the default safety timer timeout of 10.4 hours, the charger enters the topup-charge state from the CV state. Verify that DVM1 shows less than 0.15V, proportional to the charging current of less than 1A.
- 13) When the charger enters the topup-charge state, the safety timer counter is reset, and the taper timer counter starts.
- 14) If the charging current does not fall below 1A within the safety timer timeout of 10.4 hours, the charger enters a latched-fault state. In latched-fault state, DVM3 and DVM4 displays 5.1V and 0V, respectively.
- 15) In the topup-charge state, the charger continues to regulate the charging voltage. After 63 minutes, the taper timer counter elapses, charging is terminated, and the charger enters full-battery state. Verify that both DVM3 and DVM4 displays 0V.
- 16) After testing is completed, switch off the power supply and remove the connections from the EV kit.
- 17) Carefully remove the battery connection from the EV kit.

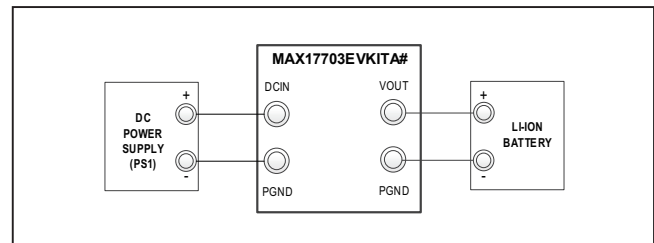

Figure 1. Battery Connection with EV Kit

MAX17703EVKITA# Evaluation Kit

Evaluates: MAX17703 in 4.2V Li-Ion Battery Charger Application

Testing with Preloaded Supply:

- 1) Set the first power supply (PS1) at a voltage between 6.3V and 60V. Disable the power supply (PS1).
- 2) Set the second power supply (PS2) at a voltage of 3.5V and current limit of 13A. Disable the power supply (PS2).
- 3) Set the electronic load (LOAD) at 12A in Constant Current (CC) mode and disable the load.
- 4) Connect PS1, PS2, and LOAD to the EV kit as shown in [Figure 2](#).
- 5) Make sure that LOAD is connected across the PS2 terminals and the connection resistance from the EV kit to the preloaded supply is not greater than 50mΩ.
- 6) Verify that the shunts are installed across pins 1–2 on all jumpers: charger enable/disable jumper (J1), CC mode charging current jumper (J2), TEMP feature jumper (J3), and safety timer jumper (J4). See [Table 1](#), [Table 2](#), [Table 3](#), and [Table 4](#) for details.
- 7) Connect the digital voltage meter (DVM1) between the ISMON PCB pad and the nearest SGND PCB pad for monitoring the charging current.
- 8) Connect DVM2 between the VOUT PCB pad and the nearest PGND PCB pad for measuring the charging voltage.
- 9) Connect DVM3 between FLG1 PCB pad and the nearest SGND PCB pad for monitoring the charger status.
- 10) Connect DVM4 between FLG2 PCB pad and the nearest SGND PCB pad for monitoring the charger status. See [Table 5](#) for details.
- 11) Turn on LOAD and PS2. Verify that 12A load current is supplied by PS2 and adjust the PS2 voltage to maintain the EV kit terminal voltage at 3.5V.
- 12) Turn on the DC power supply (PS1).
- 13) The charger starts in CC state and the safety timer starts counting. Verify that the DVM1 displays 1.5V, proportional to the 10A charging current (ICHGMAX).
- 14) In CC state, observe that DVM3 and DVM4 displays 0V and 5.1V, respectively.
- 15) Increase the voltage on PS2 in steps of 10mV to maintain the DVM2 reading at 4.1V when the charger enters CV state, and the charging current starts to fall from 10A. Verify that when DVM2 displays above 4.1V, the voltage reading on DVM1 falls from 1.5V, proportional to charging current.
- 16) Increase the voltage on PS2 such that the charging current falls below the taper current threshold, i.e., 1A. Verify that the DVM1 shows less than 0.15V, proportional to the charging current. The charger enters topup-charge state upon detecting the taper current threshold.
- 17) In topup-charge state, the charger resets the safety timer counter and starts the taper timer counter.
- 18) In the topup-charge state, the charger continues to regulate the charging voltage. After 63 minutes, the taper timer elapses, charging is terminated, and the charger enters the full-battery state. Observe that both DVM3 and DVM4 display 0V.
- 19) Reduce the PS2 voltage to less than the charger recharge threshold of 4V and observe that the charger resumes charging automatically. Verify that DVM3 and DVM4 displays 0V and 5.1V, respectively.
- 20) After testing is completed, switch off PS1 and remove the connection.
- 21) Switch off PS2 and LOAD. Carefully remove the preloaded supply connections from EV kit.

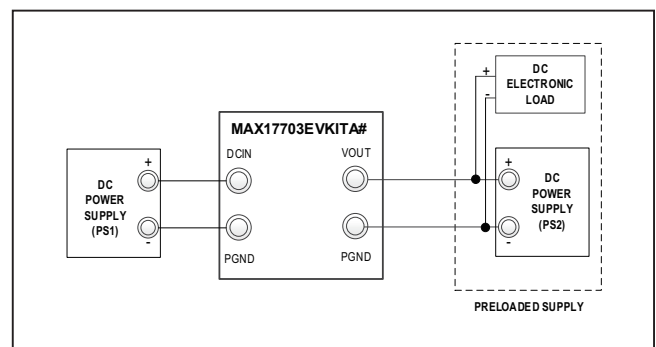

Figure 2. Preloaded Supply Connection with EV Kit

MAX17703EVKITA# Evaluation Kit

Evaluates: MAX17703 in 4.2V Li-Ion Battery Charger Application

Detailed Description

The MAX17703EVKITA# (EV kit) provides a charging solution for a 45Ahr Li-ion battery with a CC mode charging current of 10A (I_{CHGMAX}) and a CV mode voltage of 4.2V from an 6.3V to 60V input supply. The EV kit features a 350kHz switching frequency for optimum efficiency and component size. The RT/SYNC PCB pad allows an external clock to synchronize the device. The EV kit includes jumper J1 to enable/disable the controller. The FLG1 and FLG2 PCB pads allow monitoring of the charger status. The ISMON PCB pad allows monitoring of the charging current.

Enable/Undervoltage-Lockout (EN/UVLO) Programming

The EV kit offers an adjustable input undervoltage lockout (UVLO) feature. Figure 3 shows the input undervoltage lockout setting on the EV kit. The input voltage above which the charger is enabled, can be set with a resistor-divider connected to EN/UVLO from DCIN to PGND. See Table 1 for jumper J1 settings. To enable the charger and set the UVLO, install the shunt across pins 1–2 on jumper J1. To disable the charger, install a shunt across pins 2–3 on jumper J1. The $V_{DCIN(MIN)}$ is selected as 6.1V for this EV kit.

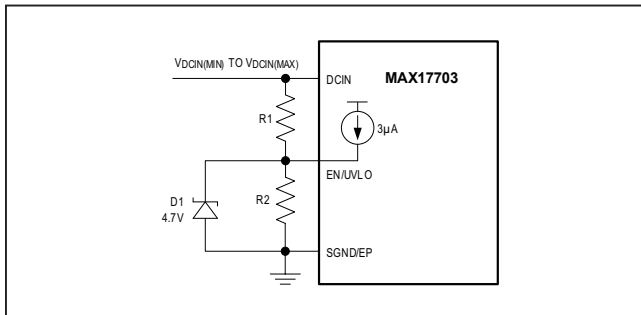

Figure 3. Setting the Input Undervoltage Lockout

Table 1. Charger Enable/Disable Jumper (J1) Settings

JUMPER	SHUNT POSITION	EN/UVLO PIN	CHARGER OPERATION
J1	1–2*	Connected to the input UVLO divider midpoint	Enabled. UVLO level is set by the resistor divider from DCIN to SGND/EP
	2–3	Connected to SGND/EP	Disabled

*Default position.

Table 2. CC Mode Charging Current Jumper (J2) Settings

JUMPER	SHUNT POSITION	ILIM PIN	I_{CHGMAX} SETTING
J2	1–2*	Connected to V_{REF}	10A
	2–3	Connected to ILIM_EXT test point	$6.67 \times V_{ILIM}$
	Not installed	Connected to ILIM resistor divider (R8 and R9) midpoint	6A

*Default position.

Choose R1 as follows:

$$R1 \leq (10000 \times V_{DCIN(MIN)})$$

where $V_{DCIN(MIN)}$ is the voltage at which the device is required to turn on.

Calculate the value of R2 using the following equation:

$$R2 = \frac{V_{EN_TH_R} \times R1}{V_{DCIN(MIN)} - V_{EN_TH_R} + (I_{EN-BIAS} \times R1)}$$

where:

$I_{EN-BIAS}$ = Internal bias pullup current on the EN/UVLO pin (3µA)

$V_{EN_TH_R}$ = EN/UVLO pin rising threshold voltage (1.25V)

For more details about setting the undervoltage lockout level, refer to the MAX17703 datasheet.

CC Mode Charging Current Setting (ILIM)

The EV kit provides the CC mode charge current programming feature. The ILIM PCB pad on the EV kit supports external control of the CC mode charging current (I_{CHGMAX}). See Table 2 for jumper J2 settings. To fix the I_{CHGMAX} at 10A, install a shunt across pins 1–2 on jumper J2. To control I_{CHGMAX} , install a shunt across pins 2–3 on jumper J2 and apply a voltage (V_{ILIM}) between the ILIM_EXT test point and nearest SGND PCB pad. The allowable voltage range on ILIM_EXT is 0.9V to 1.5V. To fix the I_{CHGMAX} at 6A, remove the shunt on jumper J2. For more details about the CC mode charging current setting, refer to the MAX17703 IC data sheet.

MAX17703EVKITA# Evaluation Kit

Evaluates: MAX17703 in 4.2V Li-Ion Battery Charger Application

Deeply Discharged Battery Detection and Preconditioning

The EV kit features deeply-discharged battery detection and preconditioning of the Li-ion battery. The deeply discharged battery voltage level is set at 3V on the EV kit as per a typical 4.2V/45Ahr Li-ion battery specification. If the battery voltage detected is less than 3V across the EV kit output, then the charger enters a precharge state. In precharge state, the charging current is set at 1/10th of ICHGMAX (1A) and the safety timer counter starts. If the EV kit output is not reached above 3V within the precharge-timer timeout (1.3 hours), the charger enters a latched-fault state. Otherwise, the charger enters CC state.

For the deeply discharged battery voltage-level setting other than 3V, R3 and R4 components needs to be changed on the EV kit. Use the following equations to calculate the required R3 and R4 values for the deeply discharged battery voltage-level setting (V_{OUTDD}).

Select R3 in the range of 50kΩ to 100kΩ.

$$R4 = \frac{R3}{\left(\frac{V_{OUTDD}}{1.25} - 1\right)}$$

For more details about the battery precharge-state detection mechanism, refer to the MAX17703 IC data sheet.

Battery Operating Temperature Range Setting (TEMP)

The EV kit features battery operating temperature range setting (TEMP) and charges only when the battery temperature is within the programmed operating temperature range using a negative temperature coefficient (NTC) thermistor. Figure 4 shows the TEMP setting on the EV kit. The battery operating temperature range setting on

the EV kit is +5°C to +45°C. See Table 3 for jumper J3 settings. To disable the TEMP feature, install a shunt across pins 1–2 on jumper J3. To enable the TEMP feature, install a shunt across 2–3 on jumper J3, and connect a 47kΩ NTC thermistor (with B-constant (25°C - 85°C) = 4108, packed out with EV kit) at the RT1 PCB footprint on the EV kit. The NTC thermistor head should be attached on the battery to sense the battery temperature.

For changing the battery operating temperature range, use the following equations to calculate the required R6 and R7 values for the desired battery operating temperature range.

$$R7 = \frac{1.25 \times R_{NTCCOLD} \times R_{NTCHOT}}{(R_{NTCCOLD} - 2.25 \times R_{NTCHOT})}$$

$$R6 = \frac{0.67 \times R_{NTCCOLD} \times R7}{(R_{NTCCOLD} + R7)}$$

where:

R_{NTCCOLD} = Resistance value of the 47kΩ NTC thermistor at minimum battery-operating temperature limit

R_{NTCHOT} = Resistance value of the 47kΩ NTC thermistor at maximum battery-operating temperature limit

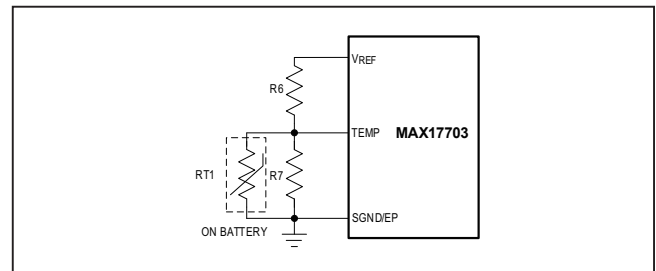

Figure 4. Setting the Battery Operating Temperature Range

Table 3. TEMP Feature Jumper (J3) Settings

JUMPER	SHUNT POSITION	TEMP CONNECTION SETTING	TEMP FEATURE
J3	1-2*	Connected to the 47kΩ resistor (R5)	Disabled
	2-3	Connected to the 47kΩ NTC thermistor (RT1)	Enabled, set the operating battery temperature range of +5°C to +45°C

*Default position.

MAX17703EVKITA# Evaluation Kit

Evaluates: MAX17703 in 4.2V Li-Ion Battery Charger Application

Charger Timers (TMR)

The EV kit features a charger timer to set the timeout in precharge, CC, CV, and topup-charge states. The charger timer setting is adjusted by the value of the capacitor between TMR and SGND/EP. The default programmed safety timer timeout in CC and CV states on the EV kit is 10.4 hours. The programmed precharge timer timeout and taper timer timeout on the EV kit are 1.3 hours (1/8th of the safety timer timeout) and 63 minutes (1/8th of the safety timer timeout), respectively. For more details on the charger state machine and charger timers, refer to the MAX17703 IC data sheet.

To enable the timer feature, install a shunt across 1–2 on jumper J4 to connect the TMR capacitor to the TMR pin. To disable the timer feature, install a shunt across pins 2–3 on jumper J4 to connect the V_{REF} to the TMR pin. See [Table 4](#) for jumper J4 settings.

To change the safety timer setting on the EV kit, the TMR capacitor need to be calculated as per the required charging time in CC and CV states from the battery charging characteristics and replace C16 with the desired TMR capacitor. Use the following equation to calculate the C_{TMR} for the required safety timer period in CC and CV states (T_{FCHG}):

$$C_{TMR} \geq 1.15 \times \left(\frac{T_{FCHG}}{2 \times t_{FCHG}} \right) \times \left(\frac{I_{TMR}}{V_{TMR_H} - V_{TMR_L}} \right)$$

where,

C_{TMR} = TMR capacitor in Farad

t_{FCHG} = Number of TMR cycles in CC and CV states (1048575)

T_{FCHG} = Desired safety timer setting in CC and CV states in seconds

V_{TMR_H} = TMR oscillator upper threshold (1.5V)

V_{TMR_L} = TMR oscillator lower threshold (0.96V)

I_{TMR} = TMR pin source/sink current (10µA).

For more details about charger timers and charger operation, refer to the MAX17703 IC data sheet.

External Clock Synchronization (RT/SYNC)

The EV kit provides an RT/SYNC PCB pad to synchronize the MAX17703 to an optional external clock. The external synchronization clock frequency must be between 0.9 x f_{SW} and 1.1 x f_{SW}, where f_{SW} is the nominal frequency of operation set by R10. The switching frequency (f_{SW}) programmed on the EV kit is 350kHz. In the presence of a valid external clock for synchronization for 112 cycles of internal switching clock, the MAX17703 starts to sync in with external clock. For more details about external clock synchronization, refer to the MAX17703 IC data sheet.

Charger Status Output (FLG2, FLG1)

The EV kit provides FLG1 and FLG2 PCB pads to indicate the charger status. [Table 5](#) shows the charger status flag summary. For more details about hardware faults, refer to the MAX17703 IC data sheet.

Table 4. Safety Timer Jumper (J4) Settings

JUMPER	SHUNT POSITION	TMR CONNECTION SETTING	SAFETY TIMER FEATURE
J4	1–2*	Connected to a TMR capacitor (0.33µF)	Enabled, set at 10.4 hours
	2–3	Connected to VREF	Disabled

*Default position.

Table 5. Charger Status Output Indications

CHARGER STATUS FLAGS (FLG2 AND FLG1)	FLG2 VOLTAGE (V)	FLG1 VOLTAGE (V)	CHARGER STATUS
11	5.1	5.1	Charger off
10	5.1	0	Charging in progress
00	0	0	Charging complete
01	0	5.1	Latched-fault or charge suspend due to high- (>45°C) or low- (<5°C) battery-temperature detection*

*A Latched-Fault state includes latched hardware faults and faulty battery states. Charge suspended due to high or low battery temperature is not a latched fault.

MAX17703EVKITA# Evaluation Kit

System Considerations

The MAX17703 EV kit is designed to charge Li-ion batteries. When the load current is drawn during the battery charging process, the charging current available for battery charging reduces. This influences the overall charging time (in CC, CV states). The safety timer timeout (T_{FCHG}) must be adjusted accordingly. Disable the timer function to charge the Li-ion batteries with a parallel system load current equal to or greater than the taper current threshold (I_{TCHG}), to avoid undesired latched-fault in CC or CV states

For safe operation, follow the procedure below while making connections:

- 1) Connect the battery terminals to the output of the charger circuit. Note that the output capacitors of the charger can draw current from the battery during a hot plug-in/connection process.
- 2) Connect the input power source to the battery charger circuit only after securely connecting the battery at the output.
- 3) Do not operate the charger without battery or pre-loaded supply.

For more details about charger operation, refer to the MAX17703 IC data sheet.

EV Kit Redesign Recommendation as per Custom Battery Charging Parameters

The MAX17703EVKITA# is designed for 45Ahr, 4.2V Li-ion battery with a charging resistance of 15mΩ. For other battery specifications, the following battery charging parameters need to be considered to redesign the EV kit application circuit.

Battery Charging Resistance

The charger controller needs to be designed according to the worst-case maximum battery charging resistance (R_{BAT}). If R_{BAT} is greater than 50mΩ, the compensation capacitor (C17) on the EV kit needs to be redesigned using the following equation:

$$C17 = \frac{0.8 \times L1}{R12 \times R_E}$$

where:

$R_E = R_{DCR} + R_S + R_{DS_ON(HS)} \times D_{MIN} + R_{DS_ON(LS)} \times (1 - D_{MIN}) + R_{BAT}$

R_{DCR} = DC resistance of inductor (L1)

R_S = Current-sense resistor value (R22)

Evaluates: MAX17703 in 4.2V Li-Ion Battery Charger Application

$R_{DS_ON(HS)}$, $R_{DS_ON(LS)}$ = Maximum on-state resistances of high-side MOSFET (Q4) and low-side MOSFET (Q3), respectively

V_{OUT} = Desired regulation voltage across the battery

V_{DCIN_MAX} = Maximum operating input voltage

$$D_{MIN} = \frac{V_{OUT}}{V_{DCIN_MAX}}$$

Battery Charging Current (I_{CHGMAX})

If the battery charging current in CC state needs to be increased greater than 10A and less than 6A, the following components on the EV kit might need to be redesigned:

- 1) Buck converter inductor (L1)
- 2) Current-sense resistor (R22)
- 3) ILIM resistor divider circuit (R8 and R9)
- 4) Input capacitance on VIN (refer to the [Schematic](#))
- 5) Output capacitance on VOUT (refer to the [Schematic](#))
- 6) Current regulation loop compensation (R12, C17, and C18)
- 7) Step-down converter nMOSFET selection (Q2, Q3, Q4, and Q5)
- 8) Input short-circuit protection external nMOSFET Selection (Q1)

For the detailed design guidelines, refer to the MAX17703 IC data sheet.

Battery Charging Voltage (V_{OUT})

If the battery charging voltage in CV state needs to be changed, the following components on the EV kit might need to be redesigned:

- 1) Battery feedback resistor divider circuit (R25 and R26)
- 2) External power-supply input for EXT-LDO (EXTVCC) connection circuit (R15 and C23)
- 3) Buck converter inductor (L1)
- 4) Input capacitance on VIN (refer to the [schematic](#))
- 5) Output capacitance on VOUT (refer to the [schematic](#))
- 6) Step-down converter nMOSFET selection (Q2, Q3, Q4, and Q5)
- 7) Input short-circuit protection external nMOSFET selection (Q1)

For detailed design guidelines, refer to the MAX17703 IC data sheet.

MAX17703EVKITA# Evaluation Kit

Evaluates: MAX17703 in 4.2V Li-Ion Battery Charger Application

Hot Plug-In and Long Input Cables

The MAX17703EVKITA# PCB layout provides an electrolytic capacitor (C15 = 68 μ F/100V). This capacitor limits the peak voltage at the input of the MAX17703 when the DC input source is “hot-plugged” to the EV kit input terminal (DCIN) with long cables. The equivalent series resistance (ESR) of the electrolytic capacitor dampens the oscillations caused by interaction of the inductance of the long input cables, and the ceramic capacitors at the charger input (VIN). An electrolytic capacitor at DCIN prevents the DCIN voltage from being less than -0.3V during input short events by providing damping with ESR.

Long Output Cables

The MAX17703EVKITA# PCB layout provides an electrolytic capacitor foot print (C10) to place an electrolytic capacitor, if required. In applications with a long cable between the MAX17703EVKITA# output and the battery, to dampen the oscillations caused by the interaction of the cable inductance with the low ESR output capacitors of the MAX17703EVKITA#, an electrolytic capacitor with appropriate ESR (equivalent series resistance) may be used.

Choose an electrolytic capacitor equal to 1.5 times the value of selected low ESR output capacitance (C_{OUT_SEL}). Select an electrolytic capacitor with the an equivalent series resistance (ESR_{ELCO}) as calculated below:

$$ESR_{ELCO} = \sqrt{\frac{L_{CABLE}}{C_{OUT_SEL}}}$$

where L_{CABLE} is the output cable inductance.

Electromagnetic Interference (EMI)

Compliance to conducted emissions (CE) standards requires an EMI filter at the input of a switching power converter-based charger. The EMI filter attenuates high-frequency currents drawn by the charger, and limits the noise injected back into the input power source.

The MAX17703EVKITA# PCB has designated footprints for the placement of conducted EMI filter components as per the optional Bill of Material (BoM). Use of these filter components results in lower conducted EMI, below CISPR 32 Class B limits. Cut open the trace at L2 before installing conducted EMI filter components. The MAX17703EVKITA# PCB layout is also designed to limit radiated emissions from switching nodes of the charger, resulting in radiated emissions below CISPR 32 Class B limits.

MAX17703EVKITA# Evaluation Kit

Evaluates: MAX17703 in 4.2V Li-Ion Battery Charger Application

MAX17703EVKITA# Performance Report

($V_{DCIN} = 24V$, $V_{OUT} = 4.2V$, $I_{CHGMAX} = 10A$, $f_{SW} = 350kHz$, $T_A = +25^{\circ}C$, unless otherwise noted.)

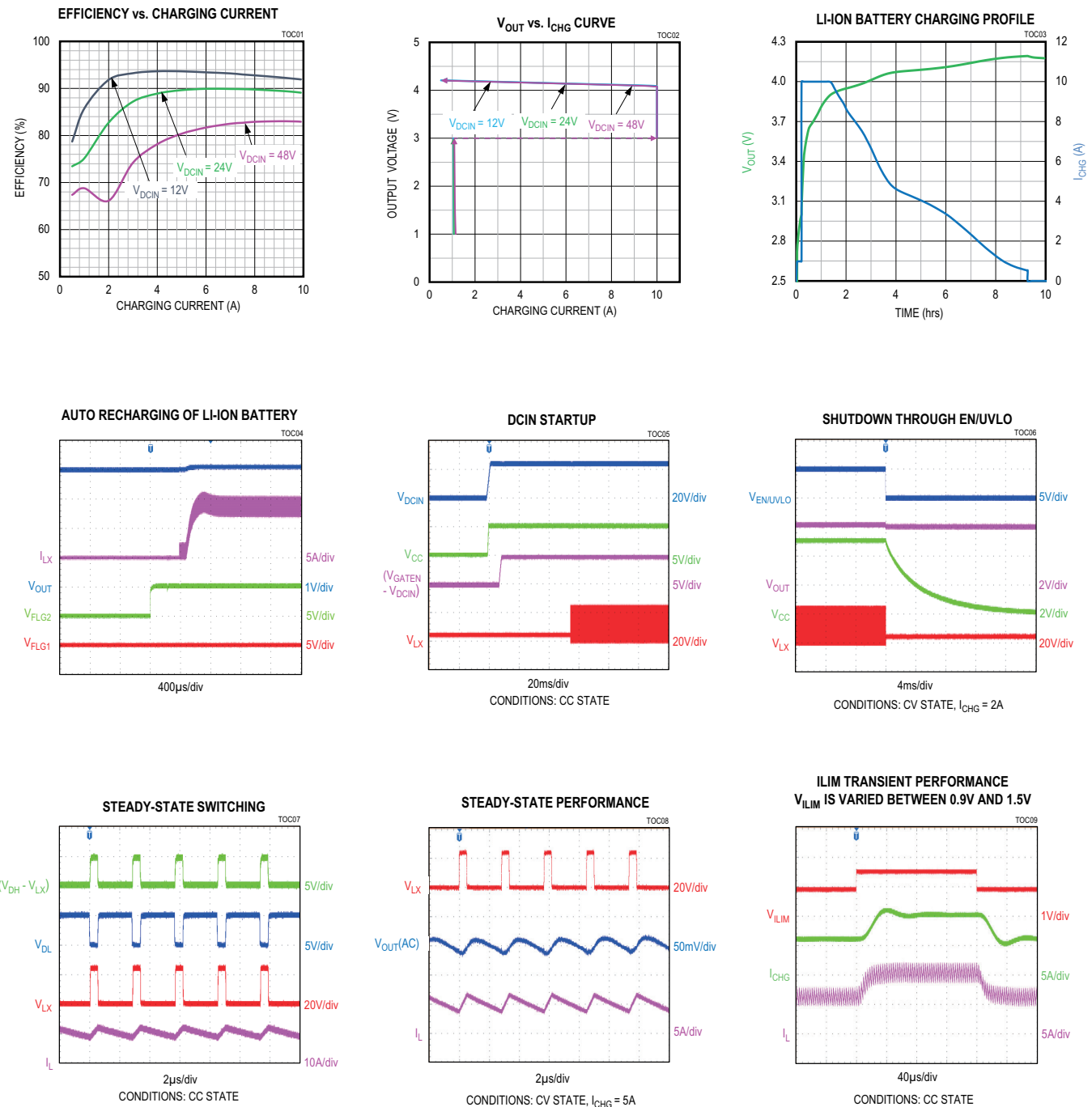

MAX17703EVKITA# Evaluation Kit

Evaluates: MAX17703 in 4.2V Li-Ion
Battery Charger Application

MAX17703EVKITA# Performance Report (continued)

($V_{DCIN} = 24V$, $V_{OUT} = 4.2V$, $I_{CHGMAX} = 10A$, $f_{SW} = 350kHz$, $T_A = +25^{\circ}C$, unless otherwise noted.)

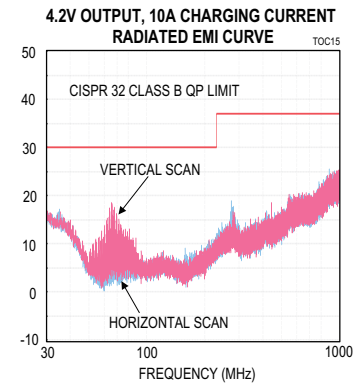
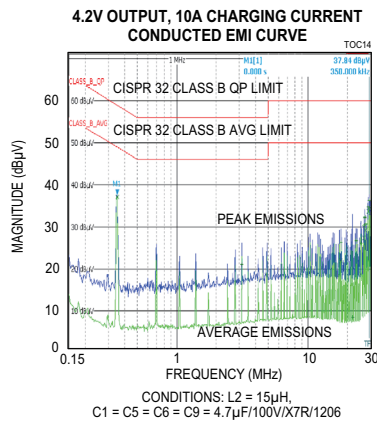
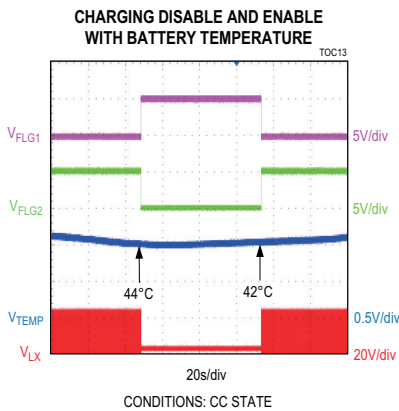
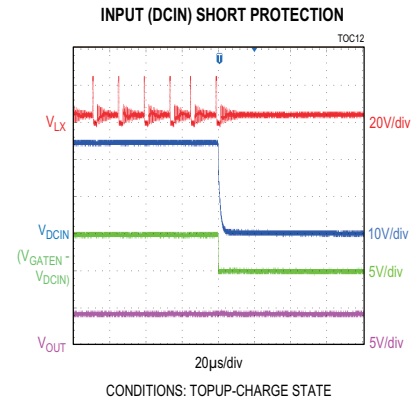
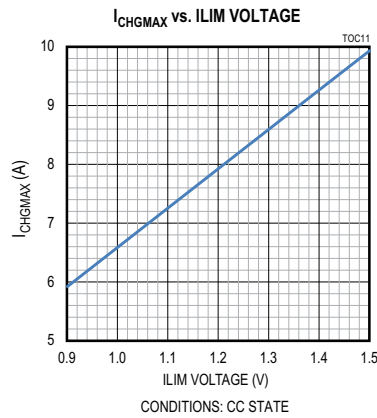
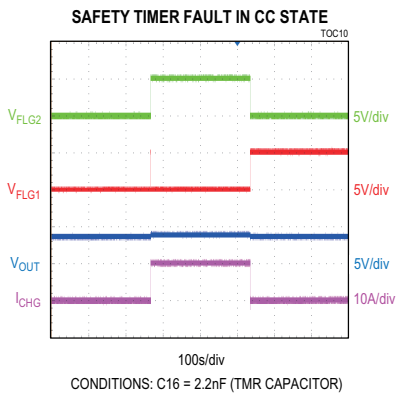

Component Suppliers

SUPPLIER	WEBSITE
Coilcraft, Inc.	www.coilcraft.com
Murata Americas	www.murataamericas.com
Panasonic Corp.	www.panasonic.com
TDK	www.tdk.com
Vishay	www.vishay.com
Taiyo Yuden	www.yuden.co.jp
Diodes Inc.	www.diodes.com
Yageo Corp.	www.yageo.com

Note: Indicate that you are using the MAX17703 when contacting these component suppliers.

Ordering Information

PART	TYPE
MAX17703EVKITA#	EV Kit

MAX17703EVKITA# Evaluation Kit

Evaluates: MAX17703 in 4.2V Li-Ion Battery Charger Application

MAX17703EVKITA# Bill of Materials

S. No	DESIGNATOR	DESCRIPTION	QUANTITY	MANUFACTURER PART NUMBER
1	C2, C11, C27, C42, C43	0.1µF, 10%, 100V, X7R, Ceramic capacitor (0603)	5	TAIYO YUDEN HMK107B7104KA
2	C3, C4, C13, C28, C40	150pF, 5%, 100V, COG, Ceramic capacitor (0402)	5	TDK C1005C0G2A151J050BA
3	C12, C31, C39	0.1µF, 10%, 16V, X7R, Ceramic capacitor (0402)	3	TAIYO YUDEN EMK105B7104KV
4	C14	10pF, 5%, 50V, COG, Ceramic capacitor (0402)	1	KEMET C0402C100J5GAC
5	C15	ALUMINUM-ELECTROLYTIC; 68µF; 100V; TOL=20%; MODEL=E2V SERIES	1	PANASONIC EEV-FK2A680Q
6	C16	0.33µF, 10%, 50V, X7R, Ceramic capacitor (0603)	1	TDK CGA3E3X7R1H334K080AB
7	C17	6800pF, 10%, 25V, X7R, Ceramic capacitor (0402)	1	YAGEO CC0402KRX7R8BB682
8	C18	82pF, 5%, 50V, COG, Ceramic capacitor (0402)	1	YAGEO CC0402JRNPO9BN820
9	C19, C20, C22, C25	4.7µF, 10%, 100V, X7R, Ceramic capacitor (1206)	4	MURATA GRM31CZ72A475KE11
10	C21	4.7µF, 10%, 16V, X7R, Ceramic capacitor (0805)	1	MURATA GRM21BR71C475KA73
11	C24	1000pF, 10%, 16V, X7R, Ceramic Capacitor (0402)	1	KEMET C0402C102K4RAC
12	C26	0.47µF, 10%, 16V, X7R, Ceramic capacitor (0603)	1	MURATA GRM188R71C474K
13	C29, C48	2200pF, 10%, 50V, X7R, Ceramic capacitor (0402)	2	MURATA GRM155R71H222KA01
14	C34	150µF, TOL=20%, 6.3V, TANTALUM CHIP	1	PANASONIC 6TPE150MI
15	C36, C37	22µF, 10%, 25V, X7R, Ceramic capacitor (1210)	2	MURATA GRM32ER71E226KE15
16	C41	47nF, 10%, 16V, X7R, Ceramic capacitor (0402)	1	MURATA GRM155R71C473KA01
17	D1	ZENER DIODE VZ=4.7V; IZ=0.005A	1	COMCHIP CZRU52C4V7
18	D2	SCHOTTKY DIODE PIV=100V; IF=1A	1	DIODES INCORPORATED DFLS1100-7
19	L1	INDUCTOR, 3.3µH, 19.4A (7mm x 7mm), 9.4mΩ	1	COILCRAFT XAL7070-332ME
20	Q1	N-CHANNEL POWER MOSFET(PowerPAK@ SO-8) PD-(6.25W); I-(95A); V-(100V)	1	VISHAY SIR170DP-T1-RE3
21	Q3, Q4	N-CHANNEL POWER MOSFET (PowerPAK@SO-8) PD-(6.25W); I-(60A); V-(80V)	2	VISHAY SIR826ADP-T1-GE3
22	R1	RESISTOR, 56.2KΩ, 1% (0603), 0.1W	1	VISHAY DALE CRCW060356K2FK
23	R2	RESISTOR, 14KΩ, 1% (0603), 0.1W	1	VISHAY DALE CRCW060314K0FK
24	R3	RESISTOR, 84.5KΩ, 1% (0402), 0.0625W	1	VISHAY DALE CRCW040284K5FK
25	R4	RESISTOR, 60.4KΩ, 1% (0402), 0.0625W	1	VISHAY DALE CRCW040260K4FK
26	R5	RESISTOR, 47KΩ, 1% (0402), 0.0625W	1	VISHAY DALE CRCW040247K0FK
27	R6	RESISTOR, 19.6KΩ, 1% (0402), 0.0625W	1	VISHAY DALE CRCW040219K6FK
28	R7	RESISTOR, 39.2KΩ, 1% (0402), 0.0625W	1	VISHAY DALE CRCW040239K2FK
29	R8	RESISTOR, 80.6KΩ, 1% (0402), 0.1W	1	PANASONIC ERJ-2RKF8062
30	R9	RESISTOR, 45.3KΩ, 1% (0402), 0.0625W	1	PANASONIC ERJ-2RKF4532
31	R11, R23	RESISTOR, 0Ω, 5% (0402), 0.0625W	2	YAGEO PHYCOMP RC0402JR-070RL
32	R12	RESISTOR, 11.5KΩ, 1% (0402), 0.0625W	1	VISHAY DALE CRCW040211K5FK
33	R13, R14	RESISTOR, 10KΩ, 1% (0402), 0.0625W	2	YAGEO PHICOMP RC0402FR-0710KL
34	R16, R18	RESISTOR, 1Ω, 1% (0402), 0.0625W	2	VISHAY DALE CRCW04021R00FK
36	R21	RESISTOR, 40.2Ω, 1% (0402), 0.0625W	1	VISHAY DALE CRCW040240R2FK
35	R22	RESISTOR, 0.005Ω, 1% (2512), 1W	1	VISHAY DALE WSL25125L000F
37	R25	RESISTOR, 42.2KΩ, 1% (0402), 0.0625W	1	YAGEO RC0402FR-0742K2L
38	R26	RESISTOR, 17.8KΩ, 1% (0402), 0.0625W	1	VISHAY DALE CRCW040217K8FK
39	U1	SYNCHRONOUS STEP-DOWN LI-ION BATTERY CHARGER CONTROLLER (TQFN24-EP 4mm x 4mm)	1	MAX17703ATG+
40	DCIN, PGND, PGND2, VOUT	BANANA JACK (5.2mm DIA X 5.5mm LENGTH)	4	KEY STONE 575-4
41	ILIM_EXT	TEST POINT, PIN DIA=0.1IN; TOTAL LENGTH=0.3IN;	1	KEY STONE 5000
42	J1-J4	3-pin header (0.1" centers)	4	SULLINS PEC03SAAN
43	-	SHUNTS	4	SULLINS STC02SYAN
44	RT1	THERMISTOR, NTC, 47KOHM, 1%, 4108K (B25°C-85°C) THROUGH HOLE-RADIAL LEAD	1 (Separate Packout with EV kit)	MURATA NXFT15WB473FA2B150
45	C1, C5, C6, C9	OPTIONAL: 4.7µF, 10%, 100V, X7R, Ceramic capacitor (1206)	4	MURATA GRM31CZ72A475KE11
46	L2	OPTIONAL: INDUCTOR, 15µH, 3.9A (5mm x 5mm), 9.4mΩ	1	COILCRAFT XAL5050-153ME
47	Q2, Q5	OPEN: PowerPAK@SO-8	0	
48	C7, C8	OPEN: CAPACITOR (1206)	0	
49	C23	OPEN: CAPACITOR (0603)	0	
50	C30, C46, C47	OPEN: CAPACITOR (0402)	0	
51	C35	OPEN: TANTALUM CAPACITOR (2917)	0	
52	C38, C44	OPEN: CAPACITOR (1210)	0	
53	C10	OPEN: ALUMINUM-ELECTROLYTIC CAPACITOR (7mmx8.5mm)	0	
54	D3	OPEN: SCHOTTKY DIODE (SMB)	0	
55	R10, R15, R17, R19	OPEN: RESISTOR (0402)	0	

DEFAULT JUMPER TABLE	
JUMPER	SHUNT POSITION
J1, J2, J3, J4	1-2

MAX17703EVKITA# Evaluation Kit

Evaluates: MAX17703 in 4.2V Li-Ion
Battery Charger Application

MAX17703EVKITA# Schematic

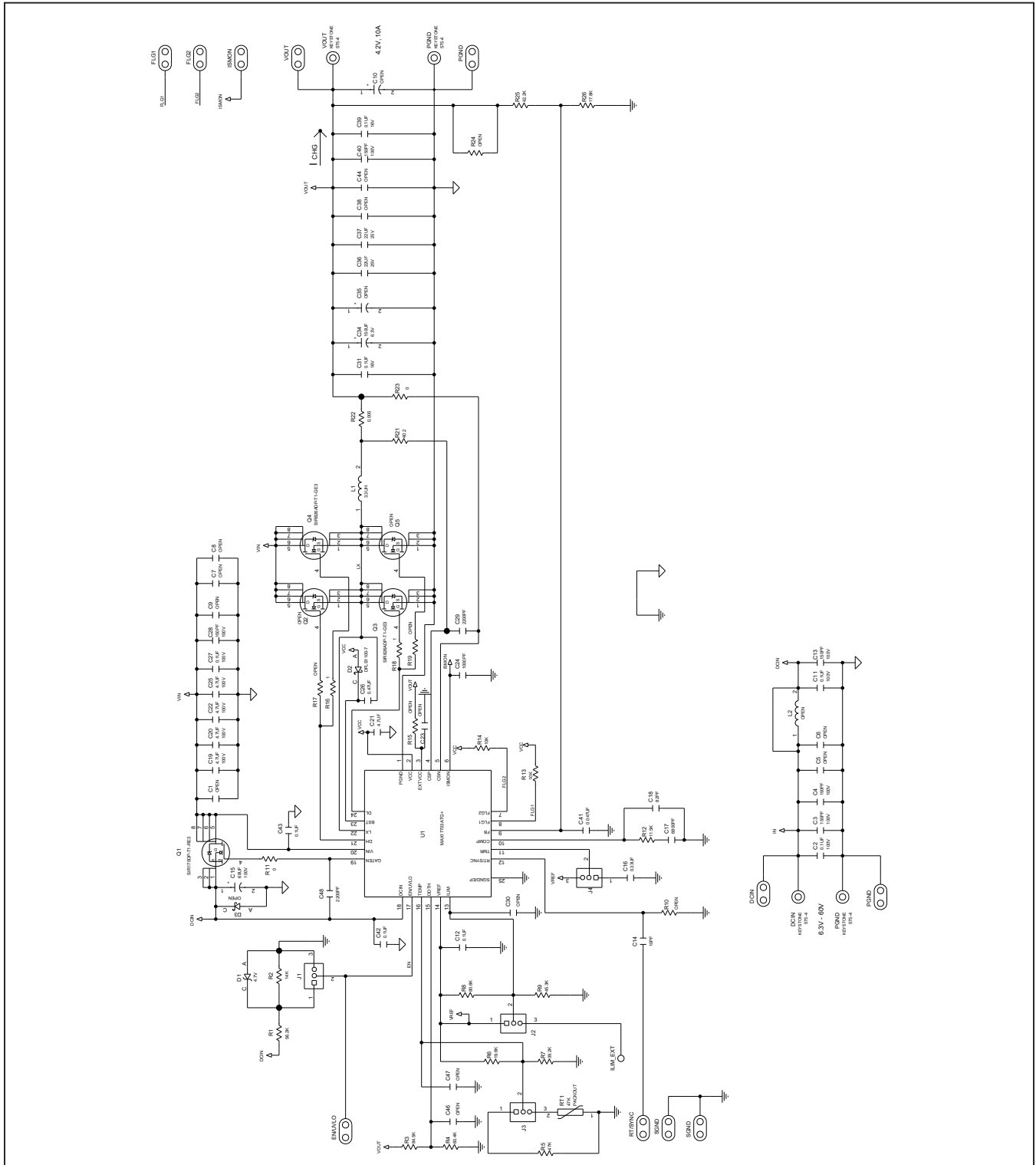

MAX17703EVKITA# Evaluation Kit

Evaluates: MAX17703 in 4.2V Li-Ion
Battery Charger Application

MAX17703EVKITA# PCB Layout

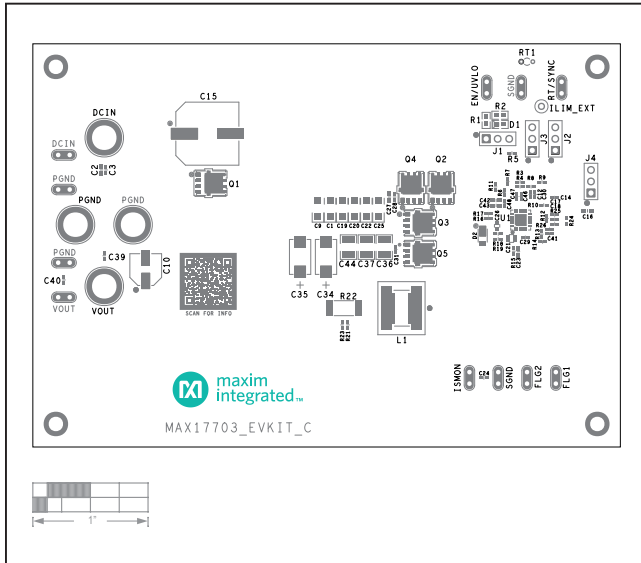

MAX17703EVKITA# PCB Layout—Top Silkscreen

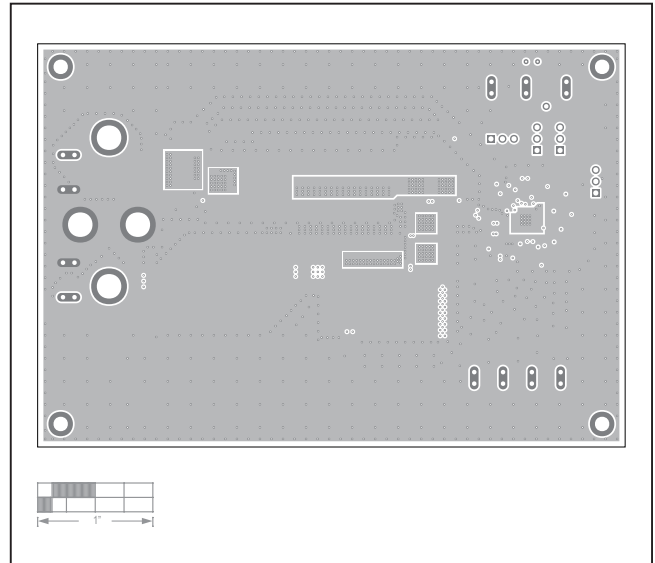

MAX17703EVKITA# PCB Layout—Layer 2

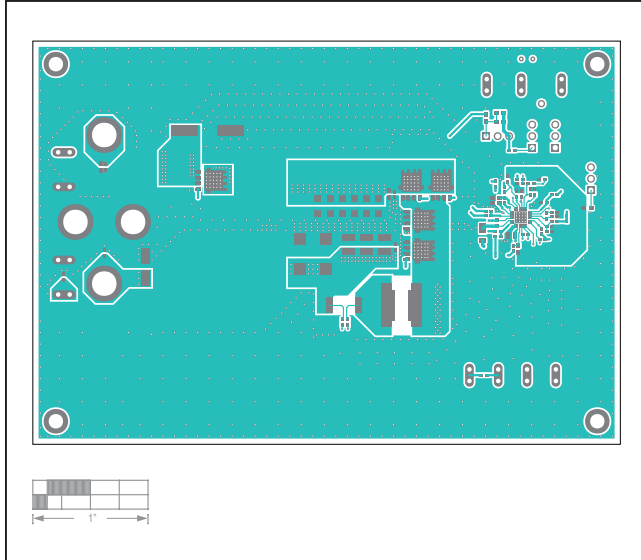

MAX17703EVKITA# PCB Layout—Top Layer

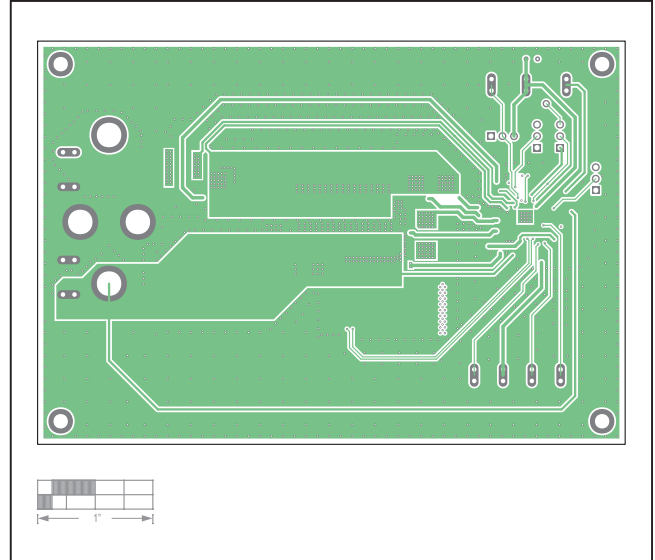

MAX17703EVKITA# PCB Layout—Layer 3

MAX17703EVKITA# Evaluation Kit

Evaluates: MAX17703 in 4.2V Li-Ion
Battery Charger Application

MAX17703EVKITA# PCB Layout (continued)

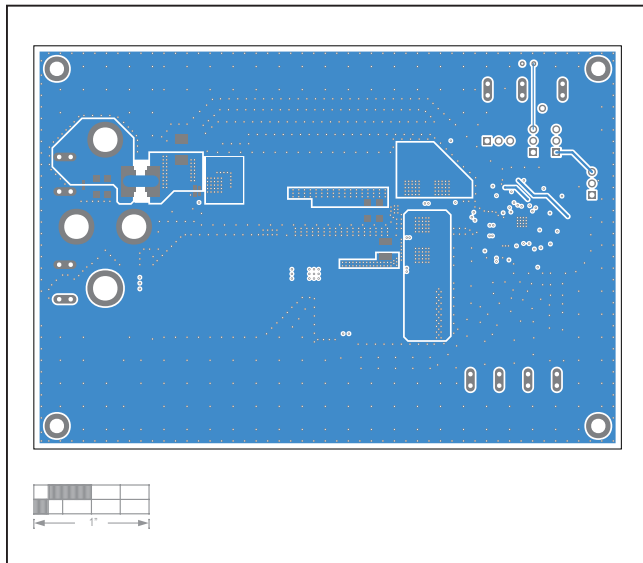

MAX17703EVKITA# PCB Layout—Bottom Layer

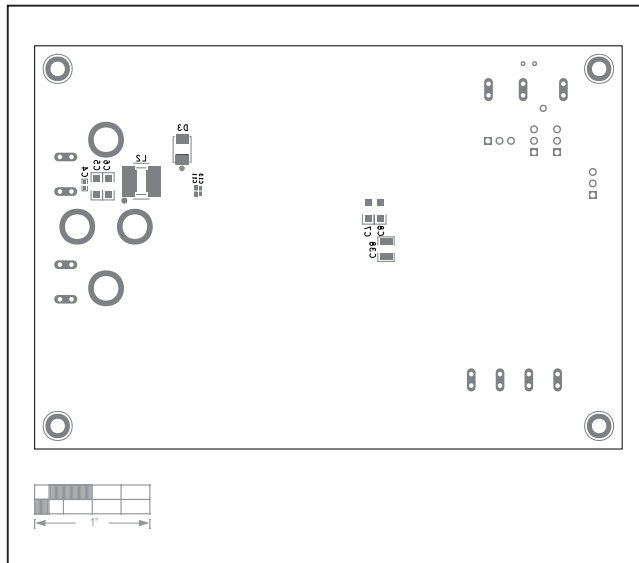

MAX17703EVKITA# PCB Layout—Bottom Silkscreen

MAX17703EVKITA# Evaluation Kit

Evaluates: MAX17703 in 4.2V Li-Ion
Battery Charger Application

Revision History

REVISION NUMBER	REVISION DATE	DESCRIPTION	PAGES CHANGED
0	4/21	Initial release	—
1	1/22	Updated <i>General Description, Features, Equipment Setup and Test Procedure, Detailed Description, TOC 1, TOC 2, TOC 4, TOC 12, Bill of Materials, Schematic, and PCB Layouts</i>	1–5, 7–14



世健系统(香港)有限公司
世健国际贸易(上海)有限公司
info@excelpoint.com.hk



世健
官方微信



世健
官方网站
www.EXCELPPOINT.com.cn



世健
商城
www.EXCELCHIPS.cn

香港 +852 2503 2212
成都 +86 28 8652 7611
济南 +86 531 8096 5769
深圳 +86 755 8364 0166
西安 +86 29 8765 1058
东莞 +86 769 8191 5827
沈阳 +86 24 3193 7067

上海 +86 10 6580 2113
福州 +86 591 8335 7003
南京 +86 25 8689 3130
苏州 +86 512 6530 8283
珠海 +86 756 8616 869
合肥 +86 139 2377 2952
无锡 +86 185 5103 2234

北京 +86 10 6580 2113
广州 +86 20 3893 9561
宁波 +86 574 8386 5759
武汉 +86 27 8769 0883
重庆 +86 136 2830 7074
惠州 +86 136 8076 4680
烟台 +86 155 5222 0532

长沙 +86 731 8220 4725
杭州 +86 571 8528 2185
青岛 +86 532 8502 6539
厦门 +86 592 5042 386
大连 +86 156 4083 6155
昆明 +86 157 9793 9565
郑州 +86 138 0384 6359